

Dear Sirs,

INVITATION TO TENDER FOR THE SUPPLY OF
Staff Room Partition Renewal

You are invited to quote for the supply of the items as specified in the enclosed tender schedule. If you are not prepared to accept a partial order, please state this clearly on the tender schedule.

Your sealed tender, in duplicate should be clearly marked on the outside envelope: Tender for Staff Room Partition Renewal.

The envelope should be addressed to “S.K.H. TSOI KUNG PO SECONDARY SCHOOL, 101 Chung Hau Street, Homantin, Kowloon” and arrive not later than 12:00pm on 24th May 2021. Late tenders will not be accepted. Your tender will remain open for 90 days from the “Closing Date”, and you may consider your tender to be unsuccessful if no order is placed with you within these 90 days. You are requested to note that unless Part II of the tender form is completed, the tender will not be considered.

If you are unable or do not wish to quote, it would be appreciated if you would return the tender form with reason to the above address at your earliest convenience.

Tender will be accepted on an *‘overall’ / ~~‘group’~~ / ~~‘itemized’~~ basis.

Yours sincerely,

(Ms.) Lam Yuk Kei
Principal

Encl.

Please delete as appropriate

TENDER

(1) Item No.	(2) Description / Specification	(3) Quantity required	(4) Unit Rate	(5) Total Amount (HK\$)	(6) Delivery Offered
1	清拆、棄置及安裝教師室Partition (詳細請看附件)	1項			

We/ I understand that if we/ I fail to supply the stores as offered in our / my tender upon accepting school's order, we are / I am prepared to pay the price difference to the school if such stores are obtained from elsewhere.

Company Chop

Name of Supplier : _____

Name and Signature of Person authorized to sign Written quotation

Name (in block letters) _____

Signature: _____

Date : _____

本校將於今年暑假期間進行教師室翻新工程，由於會涉及到教師室內天花及地板範圍，所以需要拆除全部 Partition，現誠邀 貴公司為本校更換 Partition 一事提供報價，資料如下：

- 於翻新工程進行前拆除並移走 32 套舊 Partition
- 於翻新工程完成後安裝 32 套新 Partition
- 每套 Partition 包含教師枱一張(連枱底櫃)、背櫃一個、走廊側屏風一幅、懸掛式置物平台一套、可選櫃桶或 keyboard 托盤一個
- 教師室位於一樓，無電梯
- 大致平面圖如下

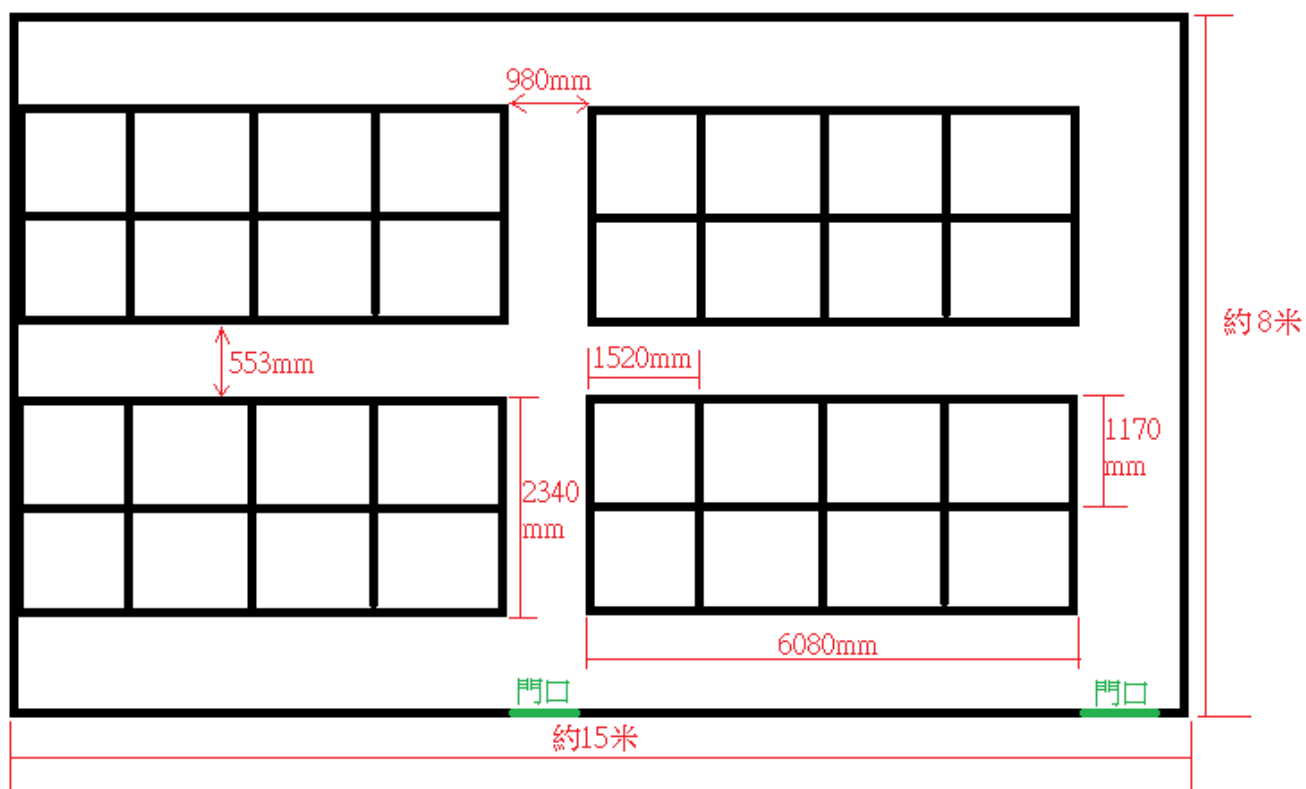

概念圖：

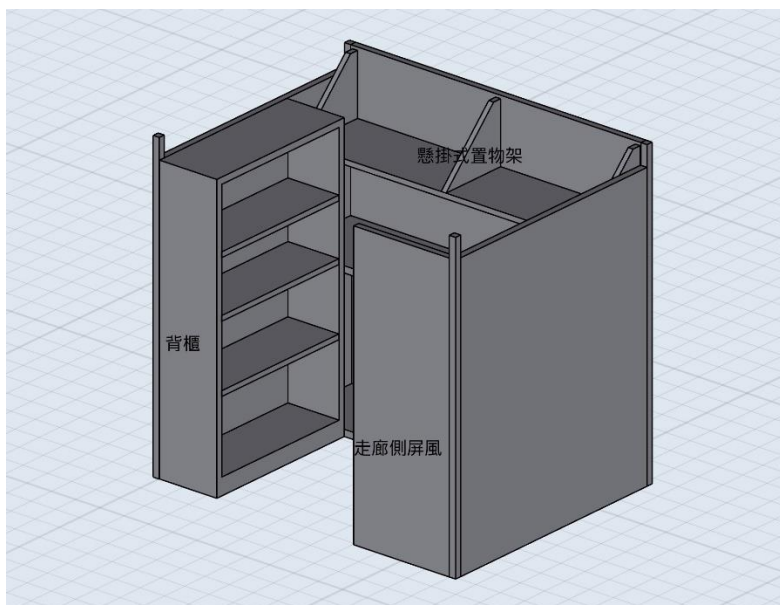
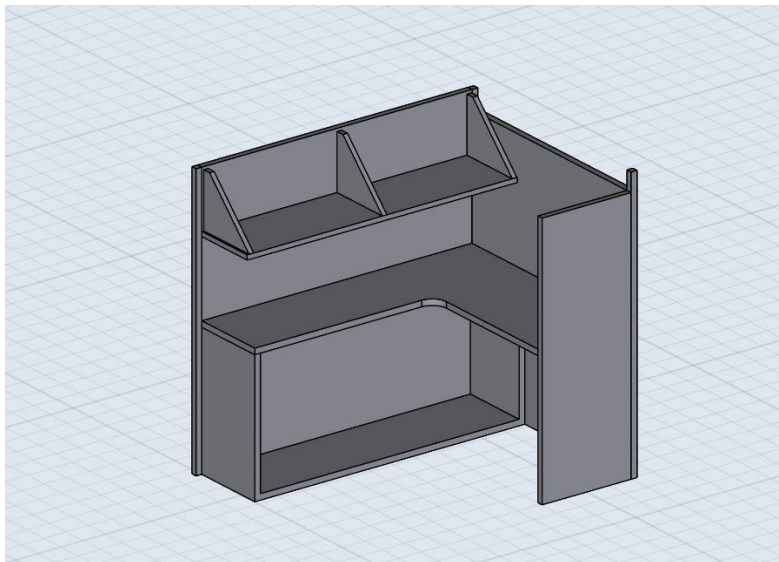
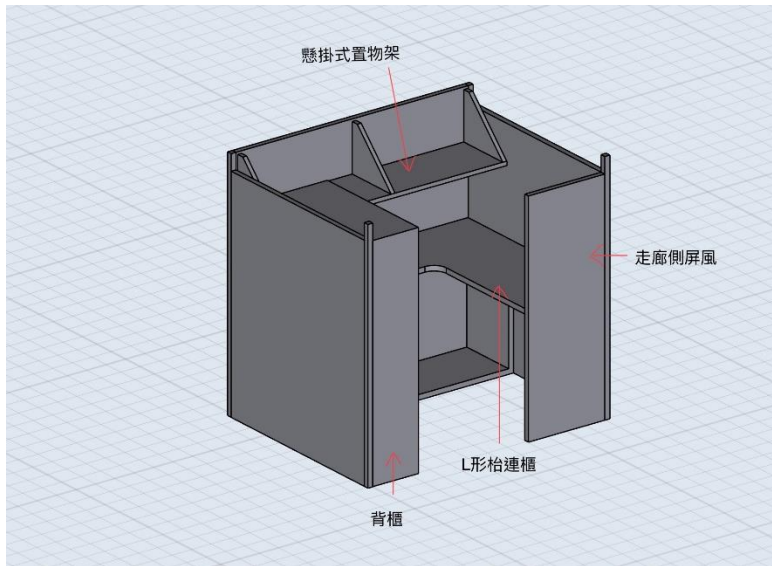

項目	工程內容	數量	金額
1	清拆及棄置教師枱，轉椅，屏風，背櫃	32 套	
2	安裝新 partition： - 屏風 - (A)L 形枱(連枱底櫃及櫃桶)，或 (B)L 形枱(連枱底櫃及 keyboard 托盤) - 背櫃 - 走廊側屏風 - 轉椅 - 懸掛式置物架	4 組 32 套 32 套 32 套 32 套 32 套 32 套	
3	上樓費(一樓)	1 項	
4	前期工程(請說明)	1 項	
5	雜項(請說明)	1 項	

報價時請註明以下項目：

1. 每項項目須列明金額
2. 施工期日數
3. 付款方法
4. 保養期

如有任何查詢，請致電 2760-0463 與馮樂斌先生聯絡。